



**PROJECT TITLE:**

**Near-Field Focusing and Collimating over a Huge Bandwidth Using Continuous Transverse Stub Antenna Arrays.**

Scientific Report on the Research Activity within the framework of the ESF program entitled "New Frontiers in Millimetre/Sub-Millimetre Waves Integrated Dielectric Focusing Systems"

**SENDING INSTITUTION:**

Departamento teoria de la senal  
Universidad Carlos III de Madrid  
Avenida la Universidad 30  
28911  
Madrid

**HOST INSTITUTION:**

Institut d'Electronique et des  
Télécommunications de Rennes (IETR),  
UMR CNRS 6164,  
Université de Rennes 1  
35042, RENNES, FRANCE

**People Involved:**

Darwin Blanco

**People Involved:**

Ronan SAULEAU

**Total Time duration: 5 months (01/01/2015-31/05/2015)**

## 1. INTRODUCTION AND MOTIVATIONS

Future Ku/Ka-band systems will be required to cover a huge demand in providing social networks services, video conferencing, private networks services, tele-medicine and/or tele-education. However the current cost of these systems could be a brake for the expansion of these. Therefore it is imperative to find low-cost solutions that lead to a speeding up of the market. Some of the Ka-band system (DVB-RCS, Docusis Sat, IPoS, etc.) [1] use circular polarization (CP) as a solution to avoid alignment during the installation process. Typically these solutions [1] use waveguide technology to create CP. An alternative solution to the expensive and bulky waveguide technology is to design the polarizer in a planar circuit board PCB technology. In this project we are interested in using the CTS antennas to produce a plane wave in the aperture of the antenna. As this antenna provides a linear polarization, we will be focusing on designing a polarizer as an add-on in order to obtain circular polarization. The final goal is to provide a broadband polarizer working in the Ku-band. The polarizer should be designed to support an angular polarization scanning up to 45 degrees. The final antenna plus polarizer is shown in Figure 1.

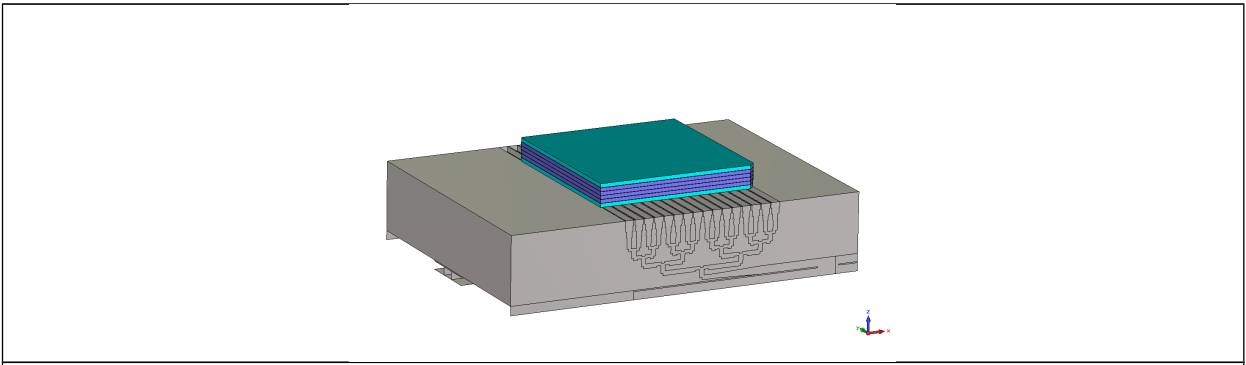

Figure 1: (a) CTS antenna plus polarizer. The CTS antenna provides the polarizer with a plane wave.

## 2. PROBLEM STATEMENT AND METHOD

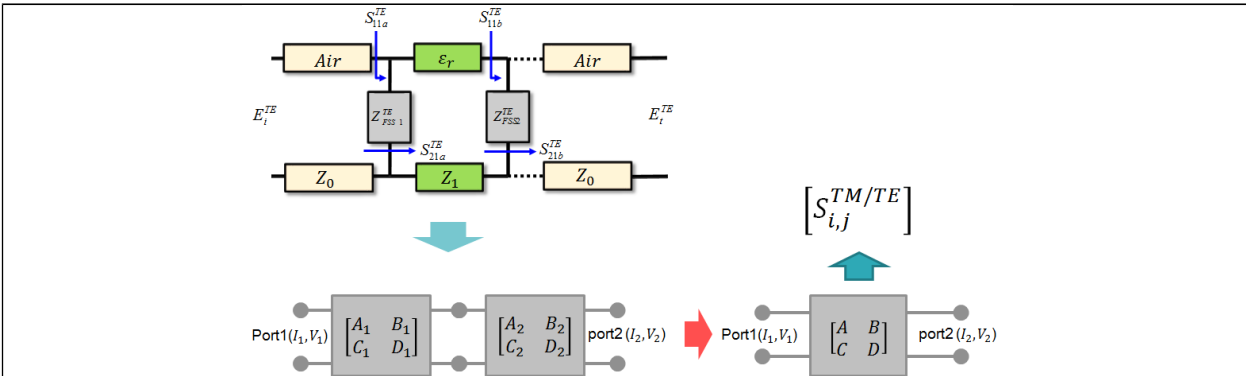

Figure 2: Transmission line model for an n-layer polarizer. This analysis allows us to know the s-parameters on the entire system.

To solve this problem we have used a hybrid optimization process. This process uses the values of the impedance provided for the software CST MW. For each impedance there exists one and only one geometry. With the simulation for n-different geometries we can make a matrix and used that to optimize the polarizer for n-layer in a home-code in Matlab. This home-code analyses the polarizer using a transmission line model TLM.

Finally a full wave optimization is done in CST to maximize the response of the broadband polarizer as a function on the incident angle.

### 3. NUMERICAL RESULTS

The first part of designing a polarizer is to choose the structure of the polarizer. We have to choose a four-layer geometry where the substrates are different to air in order to provide a better angular stability. The final geometry and description of the unit cell is shown in figure 3)a, while the axial ratio for the E-plane is shown in Figure 3)b. As it can be seen the polarizer present a broadband behavior and a stable response with the angular variation.

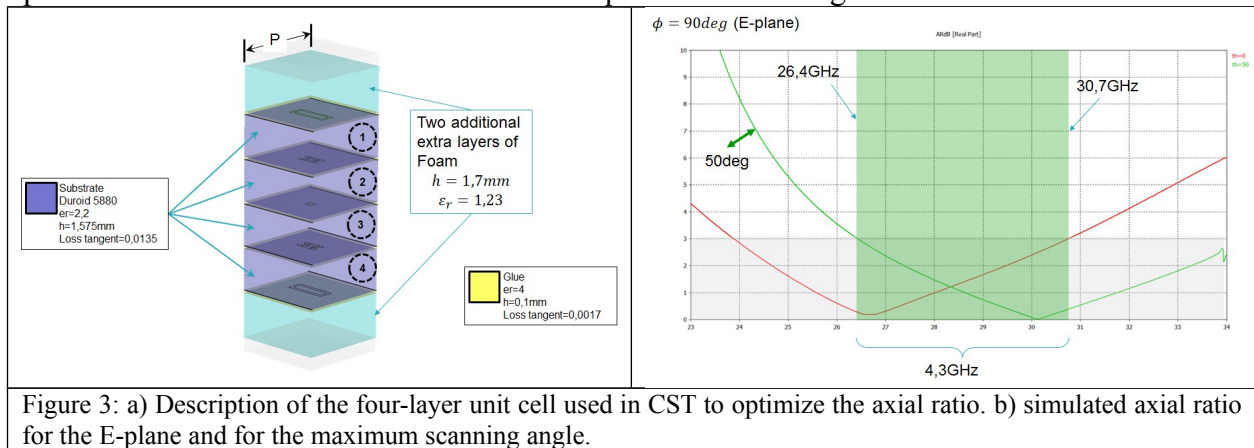

Figure 3: a) Description of the four-layer unit cell used in CST to optimize the axial ratio. b) simulated axial ratio for the E-plane and for the maximum scanning angle.

### 4. CONCLUSIONS

During this project we have completed the design of an interesting broadband polarizer for the ka-band (26-31GHz) based on a hybrid method of combining the CST MWS and the TLM modelling. The broadband polarizer is very promising since it shows strong stability as a function of the angular incidence. This final design is in process of fabrication.

As we concluded the fabrication and measurement of the prototype, we will report the results in the IEEE transaction on Antennas magazine.

In all these works, the ESF program “New Frontiers in Millimetre/Sub-Millimetre Waves Integrated Dielectric Focusing Systems” is and will be acknowledged for the received financial support.

### 5. REFERENCES

- [1] P. Chambelin and J. F. Pintos, “Design and optimization of dual and wideband polarizer for low cost ka-band applications,” Antennas and Propagation Society International Symposium 2006, IEEE, pp. 1595–1598, July 2006.
- [2] B. Munk, Finite Antenna Arrays and FSS. Wiley, 2003.
- [3] J. J. Papan, “Antenna polarizer having two phase shifting medium,” U.S. Patent No. 2978702, April 1961.
- [4] L. Young, L. Robinson, and C. Hacking, “Meander-line polarizer,” Antennas and Propagation, IEEE Transactions on, vol. 21, no. 3, pp. 376 – 378, may 1973.
- [5] F. Sanchez and R. Pearson, “Electromagnetic wave polarizer screen,” Oct. 30 2013, Patent App. EP20, 110, 799, 653. [Online]. Available: <http://www.google.com.ar/patents/EP2656441A1?cl=en>.